

Motor Mount Installation

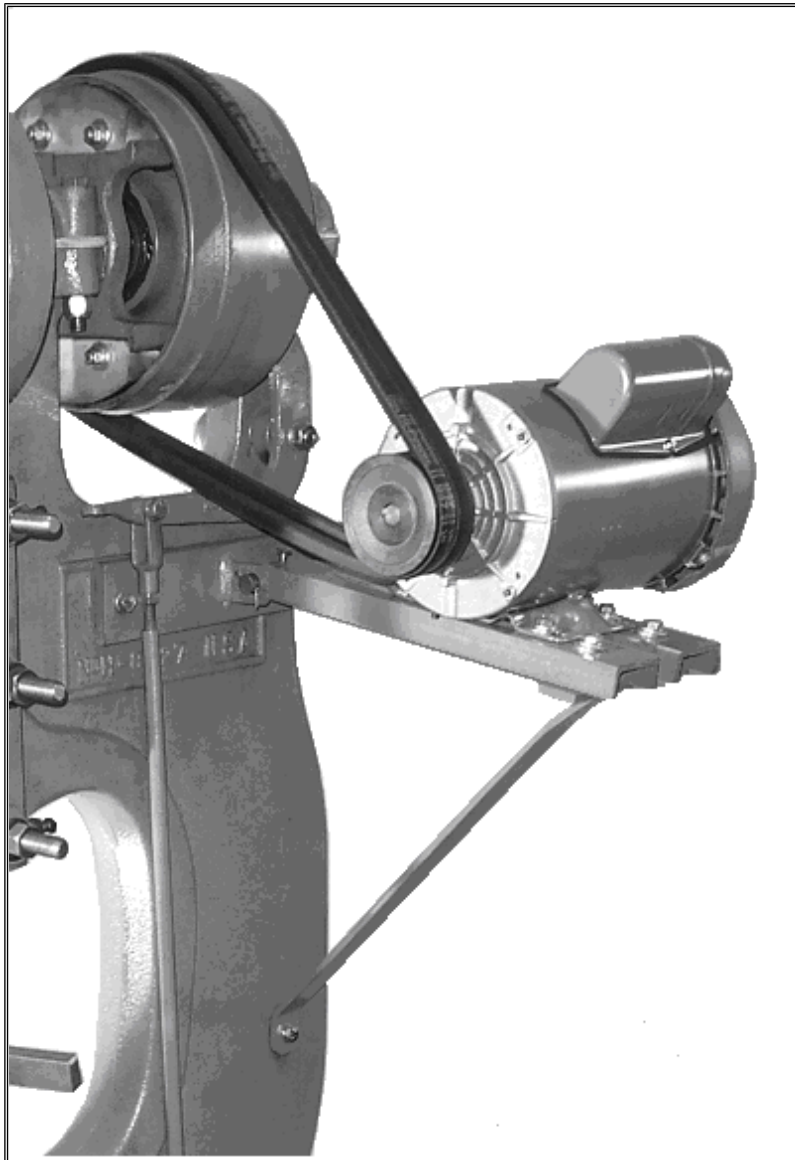

Part# Motor Mount

Please specify H, K, or P (25, 50 or 100#)

Can be used for Center or Rear clutch application!

Install the motor mount approximately 3 to 4 inches below the crotch of the frame. The left-right placement is determined by the position of the belts and pulleys on the motor. Slots cut in the rails of the motor mount allow adjustment of belt tension. The T-bracket supports the motor mount assembly; belt tensioning is done with the slots.

Little Giant DBA MMI
6414 King Road
Nebraska City, NE 68410
Email; mm21654@gmail.com
www.LittleGiantHammer.com